



Workshop equipment



**01**  
**Hand-Cleaning Lotion**  
Aquano Soft

- ▶ Item no. 2897-500-23
- ▶ Contents: 1 litre
- ▶ Packing unit: 6

- ▶ **Product description**
- Contains no abrasives
  - For dust and light soiling
  - Viscosity of soap
  - pH-value: 7
  - Dermatologically tested
  - Particularly skin-friendly
  - High-quality ingredients
  - Increased moisturising of natural oils of the skin
  - Ideal for sensitive skin
  - Suitable for frequent washing

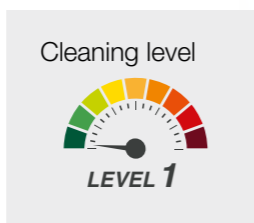

01

**02**  
**Foam soap**  
Aquano Foam

- ▶ Item no. 2897-500-25
- ▶ Contents: 1 litre
- ▶ Packing unit: 6

- ▶ **Product description**
- Skin friendly due to sugar surfactants and glycerine
  - Suitable for hand and body cleaning
  - Aqueous solution
  - A creamy foam with fine bubbles
  - Perfumed
  - pH-neutral
  - Silicone-free

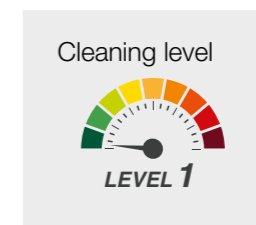

02

**03**  
**Hand Wash Paste**  
Aquano Sens

- ▶ Item no. 2897-500-240
- ▶ Contents: 1 litre
- ▶ Packing unit: 6

- ▶ **Product description**
- allergy friendly
  - suitable for particularly sensitive skin
  - for dust, dirt, oils, greases, brake dust, other light to medium soiling
  - dermatologically tested
  - pH value: 4.7-5.5
  - cleans deep into the pores
  - with lasting skin protection
  - adequate re-greasing
  - silicone- & solvent-free
  - Grating agent: walnut shell flour

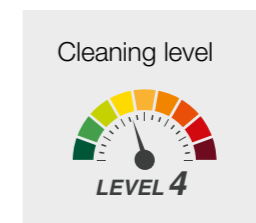

03



03

**Plastic dispenser system for Aquano**  
For 1-litre container

► Item no. 2897-500-27

► Product description

- W 108 x H 312 x D 100 mm
- for 1 L bottles
- manual operation



03

04

**Plastic dispenser system for Aquano Touchless**  
For 1-litre container

► Item no. 2897-500-26

► Product description

- W 108 x H 312 x D 100 mm
- For 1-litre bottles
- Electronic operation
- 4x Mono VARTA high-energy batteries included



04



01

**Hand protection**

Aquano Protect

- ▶ Item no. 2897-500-2
- ▶ Contents: 2 litres
- ▶ Packing unit: 1
  
- ▶ Item no. 2897-500-225
- ▶ Contents: 250 ml
- ▶ Packing unit: 1

▶ **Product description**

- Protects the skin when dealing with aqueous and non-aqueous materials such as cooling lubricants, dilute acids, alkalis, oils, grease, tar, paints, adhesives, etc.
- Quickly absorbed
- Non-greasy
- pH neutral
- Silicone-free
- Dermatologically tested
- Hypoallergenic



01

02

**Hand Cleaner**

Aquano Sens

- ▶ Item no. 2897-500-1
- ▶ Contents: 2 litres
- ▶ Packing unit: 1
  
- ▶ Item no. 2897-500-126
- ▶ Contents: 250 ml
- ▶ Packing unit: 1

▶ **Product description**

- Cleaning stage 4 of 8
- Abrasive: Polyurethane (PU)
- for dust, dirt, oils, greases, brake dust, other light to medium soiling
- pore-deep cleaning and lasting skin protection
- Viscosity medium pasty
- pH value: 6-6.5
- dermatologically tested
- adequate re-greasing
- silicone-free
- allergy friendly

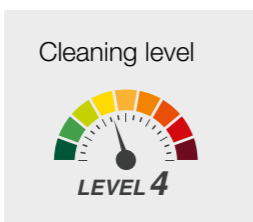

02

03

**Hand-washing paste with maize cob powder**

Aquano Corn

- ▶ Item no. 2897-500-12
- ▶ Contents: 2 litres
- ▶ Packing unit: 1

▶ **Product description**

- Cleaning stage 5 of 8
- Abrasion: Corncob meal
- For dust, dirt, oils, grease, brake dust, other light to medium soiling
- Viscosity medium pasty
- pH-value: 7
- Dermatologically tested
- For medium to heavy soiling
- Dermatologically tested and hypoallergenic
- Good moisturising
- Does not block any drains
- Suitable for different dispenser systems
- Natural abrasive maize flour, which is ecologically degradable and doesn't leave residues
- Good price-performance ratio
- Silicone-free

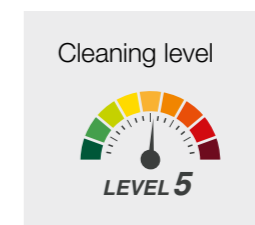

03

04

**Hand cleaner with walnut shell powder**

Aquano Peel

- ▶ Item no. 2897-500-10
- ▶ Contents: 2 litres
- ▶ Packing unit: 1

▶ **Product description**

- Cleaning stage 6 of 8
- Abrasion: Walnut shell flour
- For dust, dirt, oils, grease, brake dust, other light to medium soiling
- Viscosity medium pasty
- pH-value: 4.8 - 5.5
- Dermatologically tested – ECO Label
- Also suitable for sensitive skin
- Free from microplastics
- Environmentally friendly
- Good moisturising
- Dermatologically tested and hypoallergenic
- Does not block any drains
- Silicone-free
- Colour: light-brown
- Fragrance: orange/ lemongrass

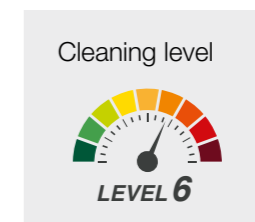

04

01

**Special hand cleaner with walnut shell granules**

Aquano Peel Spezial

- ▶ Item no. 2897-500-11
- ▶ Contents: 2 litres
- ▶ Packing unit: 1

▶ **Product description**

- Cleaning stage 8 of 8
- Abrasion: Walnut shell flour
- Solvents
- For dust, dirt, oils, grease, brake dust, other light to medium soiling
- Viscosity medium pasty
- pH-value: 7
- Dermatologically tested
- Hypoallergenic
- Suitable for different dispenser systems
- Contains environmentally friendly and skin-friendly ester oils for support with cleaning
- The natural abrasives do not block drains
- Contains natural and synthetic lipid moisturising agents

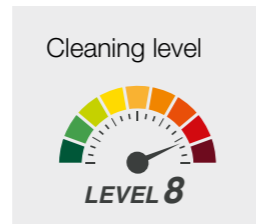

01

02

**Aquano disinfectant gel**

- ▶ Item no. 2897-500-13
- ▶ Contents: 2 litres
- ▶ Packing unit: 1

▶ **Product description**

- Fingerprints on objects are reduced
- Has a disinfecting effect
- Free of preservatives and fragrances
- Silicone-free
- Dermatologically tested
- DGHM/VAH listed



02

03

**Skin Care**

Aquano Lotion

- ▶ Item no. 2897-500-325
- ▶ Contents: 250 ml
- ▶ Packing unit: 1

- ▶ Item no. 2897-500-3
- ▶ Contents: 2 litres
- ▶ Packing unit: 1

▶ **Product description**

- Promotes the regeneration of affected areas of skin
- Suitable for the entire body
- With natural oils and vitamin E
- Non-greasy
- pH-neutral
- Slightly perfumed
- Silicone-free
- Dermatologically tested
- Hypoallergenic



03

01

**Aquano skin protection set**

7-piece kit

▶ Item no. 2897-500-001

## ▶ Technical specifications

- Set for optimal skin protection
- Products dermatologically tested
- Products suitable for allergy sufferers

-

## - Content:

- 1x skin protection Aquano Protect 2 litres (art.-No. 2897-500-2)
- 1x hand cleaner Aquano Clean 2 litres (art.-No. 2897-500-1)
- 1x skin care lotion Aquano Lotion 2 litres (art.-No. 2897-500-3)
- 1x skin protection chart (art.-No. 2897-500-7)
- 3x system dispensers (art.-No. 2897-500-6)



01



02

**Dispenser for system bottles**

for 2-litre soft bottles

▶ Item no. 2897-500-6

## ▶ Technical specifications

- Comes with a pre-installed pump for dispensing hand protection products
- Made from plastic

-

## - Scope of delivery:

- 1 x system dispenser
- 4 x 6 mm dowel, stainless-steel screws and washers
- 1 x key
- 1 x rotating head
- 1 x dosing piece
- 1 x set of installation and operating instructions



02

03

**Nail brush**

Bristle type: hard

▶ Item no. 2897-500-9

## ▶ Technical specifications

- Bristle length: 17 mm
- Colour: black
- Dimensions (H x L x W): 38 mm x 48 mm x 118 mm
- Max. cleaning temperature: +121° C
- Product meets EU Regulation no. 10/2011 regarding food contact: YES



03

01

**Care Protect**

The invisible glove

- ▶ Item no. 2897-240-1
- ▶ Contents: 1 litre of lotion
- ▶ Packing unit: 1

▶ Product description

- Lies on the skin like an invisible protective glove
- Protects the skin when dealing with various materials such as cooling lubricants, dilute acids, alkalis, oils, grease, tar, bitumen and much more
- Silicone-free
- pH skin neutral
- Dermatologically tested
- Non-greasy



01

03

**Hand cleaning Paste**

Removes dirt, such as oil, grease, etc.

- ▶ Item no. 2897-240-8
- ▶ Contents: 10 kg jumbo pail
- ▶ Packing unit: 1

▶ Product description

- Cleaning stage 2 of 8
- Abrasion: Sawdust
- For dust, light oil, light grease and other light to medium soiling
- Viscosity pasty
- pH-value: 5.6 - 5.8
- Dermatologically tested
- Silicone-free
- Alkali free

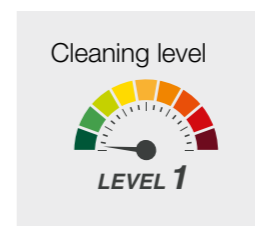

03

02

**Care Soft**

Hand-Cleaning Lotion

- ▶ Item no. 2897-240-3
- ▶ Contents: 1 litre
- ▶ Packing unit: 1

▶ Product description

- Cleaning stage 1 of 8
- Contains no abrasives
- For dust and light soiling
- Viscosity of soap
- pH-value: 7
- Dermatologically tested
- Particularly skin-friendly
- High-quality ingredients
- Increased moisturising of the skin
- Ideal for sensitive skin
- Suitable for frequent washing

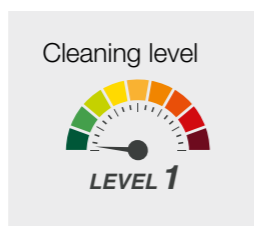

02

04

**Hand cleansing cream**

Care Truck

- ▶ Item no. 2897-240-9
- ▶ Contents: 3 litres
- ▶ Packing unit: 1

▶ Product description

- Cleanses dirty skin powerfully, deep into the pores and gentle to the skin
- effectively removes hard crunchy soiling such as oils, greases, lubricants, resins, bitumen, soot, synthetic resin, nitro and gravure inks etc.
- with shea butter for very good refatting
- cleanses extremely dirty skin deep into the pores and is gentle to the skin
- silicone-free and dermatological with „very good
- without mineral oils
- fresh scent of orange
- Grating agent: corncob and walnut husk flour

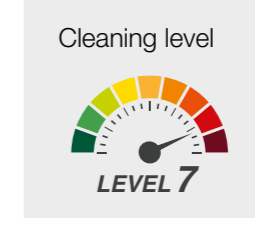

04



01

**Care Clean Corn**

Hand cleaner

- ▶ Item no. 2897-240-011
- ▶ Contents: 1 litre
- ▶ Packing unit: 10
  
- ▶ Item no. 2897-240-0
- ▶ Contents: 3 litre bucket
- ▶ Packing unit: 1

▶ **Product description**

- effectively removes heavy soiling such as oil, grease, dust etc.
- cleans deep into the pores
- with lasting protective effect
- balanced refatting
- silicone- and solvent-free
- dermatologically tested
- pH value 5.6-5.8
- Grating agent: finely ground corncob flour 01
- it is a waste product, so there is no competition with food
- Corncob meal does not block drains

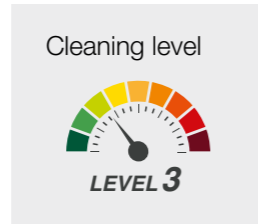

02

**Care Lotion**

Skin Care

- ▶ Item no. 2897-240-2
- ▶ Contents: 1 litre
- ▶ Packing unit: 1

▶ **Product description**

- Slightly moisturising skin care lotion Promotes the regeneration of stressed and dry skin Absorbs into skin quickly
- Promotes the regeneration of stressed and dry skin
- Silicone-free pH-neutral Dermatologically tested

02



03

**Care dispenser**

For 1-litre bottles

- ▶ Item no. 2897-240-6

▶ **Technical specifications**

- Dispenser for Care 1-litre bottles
- Fits articles 2897-240-3, 2897-240-1 and 2897-240-2

Suitable for:



03



04

**Care dispenser**

For Care-Soft 1 litre

- ▶ Item no. 2897-240-4

▶ **Technical specifications**

- One dispenser unit for Care Soft 1 litre bottle (2897-240-3)

Suitable for:



04



01

**Care dispenser**

For 3-litre tub of Care Clean

► Item no. 2897-240-7

► Technical specifications

- Dispenser for Care Clean 3-litre tub
- Fits article 2897-240



Suitable for:



01

02

**Care wall-mounted cage & dispenser**

For 3-litre tubs

► Item no. 2897-240-10

► Technical specifications

- Wall holder with integrated dispenser for Care Clean 3 litre tub



02

03

**Care wall-mounted cage**

For 1-litre bottles

► Item no. 2897-240-5

► Technical specifications

- Wall holder for Care 1 litre bottles
- Suitable for articles 2897-240-1, 2897-240-3 and 2897-240-2



03

04

**Care wall-mounted combi cage**

For the complete system

► Item no. 2897-240-15

► Technical specifications

- For Care Protect and Care Lotion (1-litre bottles)
- For Care Clean (3-litre tubs)



04

01

**Automatic dispenser for paper rolls**

- ▶ Item no. 2897-600-3
- ▶ Colour: White
  
- ▶ Item no. 2897-600-31
- ▶ Colour: Silver

▶ **Technical specifications**

- High-quality paper dispenser for an attractive appearance in the sanitary area.
- 371 x 221 x 330 mm
- 4 x mono batteries are required (Art.-No. 3722-01)
- suitable paper roll: 205 x 152 mm (Art.-No. 2897-600-7)



02

**Paper roll**

for automatic dispenser (Art.-No. 2897-600-3/31)

- ▶ Item no. 2897-600-7

▶ **Technical specifications**

- 2-ply
- 6 rolls a 400 sheets per carton
- Sheet size: 380 x 205 mm
- Packaging dimensions: 200 x 205 x 200 mm
- Weight: 2 x 18.5 g/m<sup>2</sup>
- Ø roll: 200 mm
- Roll size: 205 x 152 mm



02

03

**Foam soap dispenser**

- ▶ Item no. 2897-600-2
- ▶ Colour: White
  
- ▶ Item no. 2897-600-21
- ▶ Colour: Silver

▶ **Technical specifications**

- 345 x 112 x 306 mm



04

**Folded towel paper**

white, for paper dispenser (Art.-No. 2897-600-2 / -21)

- ▶ Item no. 2897-600-6

▶ **Technical specifications**

- product description
- 2-ply
- 21 pieces a 110 sheets in carton
- Sheet size: 340 x 235 mm
- Packaging size: 85 x 130 x 235 mm
- Weight: 2 x 20.9 g/m<sup>2</sup>



04

01

**Foam soap dispenser**

- ▶ Item no. 2897-600-1
- ▶ Colour: White
  
- ▶ Item no. 2897-600-11
- ▶ Colour: Silver
  
- ▶ Technical specifications
- 232 x 114 x 124 mm

**Foam soap**

500 ml for dispenser (Art.-No. 2897-600-1 / -11)

- ▶ Item no. 2897-600-5



02

**Rubbish bin**

- ▶ Item no. 2897-600-4
- ▶ Colour: White
  
- ▶ Item no. 2897-600-41
- ▶ Colour: Silver

## ▶ Technical specifications

- High-quality paper bucket for an attractive appearance in the sanitary sector.



01

**Special glove „FLEX PRO“**

► **Product description**

- oil-resistant
- nitrile coated
- grey carrier material made of special stretch knitted fabric
- with knitted waistband
- very slip-resistant
- silicone-free
- EN 420, EN 388 CAT 2
- Power value 4121
- application areas:
- body work
- engine compartment
- Metal processing
- Automotive and commercial vehicle industry
- medium mechanical loads,
- good dry grip and good mechanical properties
- Resistance required in parts of the construction industry



Item no.	Model
7798-017-8	Size 8
7798-017-9	Size 9
7798-017-10	Size 10
7798-017-11	Size 11

03

**\*\*Protective gloves „MECHANIK“**

► **Technical specifications**

- excellent grip in dry and wet conditions
- wet working environment
- special surface profiling through foamed, black latex coating
- very good sense of touch
- very good fit
- Skin-friendly and seamless nylon knit lining
- good mechanical load-bearing capacity
- EN Standards / Performance values:
- EN 388
- Category II
- Power value 3121



Item no.	Model
7798-004-8	Size 8
7798-004-9	Size 9
7798-004-10	Size 10
7798-004-11	Size 11

02

**Special gloves „Flex-Pro+“**

► **Product description**

- oil-resistant
- nitrile coated
- for fine motor activities
- Nubs in the palm of the hand
- excellent fit
- Production according to EN420, EN388 CAT2



Item no.	Model
7798-021-11	Size 11
7798-021-9	Size 9
7799-021-10	Size 10
7799-021-8	Size 8

04

**Nitrile protective gloves „BLUE“**

► **Technical specifications**

- double coating (lower: Nitrile- full coating, upper: sanded nitrile)
- partly coated on palm and fingertips
- Highest dexterity
- knitted waistband
- water repellent
- perfect oil handle
- EN Standards 420/388
- Power value 4121



Item no.	Model
7798-006-8	Size 8
7798-006-9	Size 9
7798-006-10	Size 10
7798-006-11	Size 11

01

**Interior knitted gloves „SKIN**

► **Technical specifications**

- perfect wearing comfort
- very good dexterity
- touchscreen capable
- with knitted waistband
- blue, black PU coating on palm and fingertips
- Nylon fabric with 18 GAUGE knitting



01

Item no.	Model
7798-002-8	Size 8
7798-002-9	Size 9
7798-002-10	Size 10
7798-002-11	Size 11



02

**PU protective gloves „TOP**

► **Technical specifications**

- PU-coated on palm and fingertips
- Nylon glove
- seamless
- very good wearing comfort
- great flexibility and sense of touch
- slip and abrasion resistant
- very good fit
- EN Standards / Performance values:
- EN 388
- Kat. II
- performance value 4131



02

Item no.	Model
7798-001-8	Size 8
7798-001-9	Size 9
7798-001-10	Size 10
7798-001-11	Size 11

03

**Interior gloves „NAPS**

► **Technical specifications**

- Nylon/Cotton
- circular knitted
- blue PVC knobs on one side
- grip-proof
- breathable
- very good fit
- washable
- EN Standards / Performance values:
- EN 388
- Category 2
- Power value 4141



03

Item no.	Model
7798-003-8	Size 8
7798-003-9	Size 9
7798-003-10	Size 10
7798-003-11	Size 11

01

**Protective gloves „CUT PRO“**

► **Technical specifications**

- highest cut protection level 5
- special fibre knitted glove
- Colour: grey
- silicone-free
- black nitrile coating on palm and palm and fingertips
- with knitted waistband
- highest wearing comfort
- Highest dexterity
- Production according to EN388 CAT2 & EN407
- Protection values 4542
- Contact heat 1



Item no.	Model
7798-022-8	Size 8
7798-022-9	Size 9
7798-022-10	Size 10
7798-022-11	Size 11

03

**Anti-Shock glove**

Outer material: synthetic leather and elastane

► **Technical specifications**

- Perfect fit and secure grip
- Good wear and touch properties
- Maximum protection
- For high-vibration and impact work with hammer drills, pneumatic and drilling equipment, heavy tools, etc.
- Padded flexible yellow elastane back
- 3 mm shock-absorbing gel inlays with Clarino® synthetic leather, reinforced fingertips with extra-large anti-slip pads made from silicone
- Knuckle protection
- Palm area made from breathable Clarino® synthetic leather
- Standards: EN 388 CAT II



Item no.	Model
7798-030-9	Size M
7798-030-10	Size L
7798-030-11	Size XL

02

**PU protective gloves „CUT“**

► **Technical specifications**

- PU coating on the palm of the hand and the fingertips
- flexible
- excellent sense of touch
- high abrasion resistance
- good cut protection (level 3) due to Dyneema fiber
- mechanical load-bearing capacity
- EN Standards / Performance values:
- EN 388
- performance value 4343



Item no.	Model
7798-005-8	Size 8
7798-005-9	Size 9
7798-005-10	Size 10
7798-005-11	Size 11

04

**Elastic adhesive bandage**

Flexi-Tape

► **Item no. 7695-50-45**

► **Product description**

- Dimensions: Length 4.50 m, width 50 mm
- Adhesive bandage
- Ideal for injuries to hands and fingers
- Resistant to water and other liquids
- Elastic and tearable



04

01

**„Elektro“ protective gloves**

## ► Product description

- insulating glove made of red natural latex
- protection against voltage up to 1000 Volt
- CE CATEGORY: III Irreversible damage
- complies with standards: EN 60903-2003, CEI 903-2002
- Category AZCv
- length: 41cm
- Thickness: 1mm
- harmless: conforms to European standards
- Touch feeling: Class 0



01

Item no.	Model
7797-020-9	Size 9
7797-020-10	Size 10

02

**„Chemical“ butyl protective gloves**

## ► Product description

- Highly impermeable against steam, gases and toxic chemicals
- Highly resistant to dipolar compounds such as esters, ketones, aldehydes, amines, saturated salt solutions and acids and alkalis
- EN 374 and EN 388



02

Item no.	Model
7797-028-10	Size 10

03

**Cleaning gloves „CHEMIE“**

## ► Technical specifications

- Chemical protective gloves
- Nitrile
- length 32 cm
- velourized
- packed in pairs in polybags
- for food contact



03

Item no.	Model
7798-022-8	Size 8
7798-022-9	Size 9
7798-022-10	Size 10
7798-022-11	Size 11

04

**\*PVC protective gloves „CHEMIE“**

## ► Product description

- Universal, light protection against chemicals and liquids, such as against numerous alkalis, acids, oils, etc.
- 100% impermeable to liquid
- Secure grip thanks to diamond pattern
- Anti-bacterial
- Silicone-free
- Length: 32 cm



04

Item no.	Model
7798-010-10	Size 10





01  
**Nitrile protective gloves „YELLOW“**

- ▶ Technical specifications
- light assembly glove with nitrile partial coating
- good dry grip
- Cotton jersey with knitted waistband
- European quality
- manufacturer information:
- EN standard 388
- Cat. 2
- Power value 4121



Item no.	Model
7798-007-8	Size 8
7798-007-9	Size 9
7798-007-10	Size 10
7798-007-11	Size 11

02  
**Latex work gloves „Winter“**

- ▶ Product description
- Palm PVC coated
- Fingertips with latex coating
- With winter lining
- Level 2 cut resistance
- Neon orange
- Water repellent, water tight for up to 30 minutes
- Performance value 3221
- DIN EN 511



Item no.	Model
7797-025-11	Size 11

03  
**Latex protective glove winter „COLD“**

- ▶ Technical specifications
- moisture repellent and insulating
- roughened for better grip
- produced according to EN 388 & EN 511
- Protection values: 2241



Item no.	Model
7798-011-8	Size 8
7798-011-9	Size 9
7798-011-10	Size 10
7798-011-11	Size 11



01

**Disposable gloves „LATEX“**

## ► Technical specifications

- latex
- powder-free
- unshabby
- can be worn on both sides
- Category: T. 1 - 3, AQL 1.5
- manufactured according to EN 455
- 100 pcs. per box
- food approval



01

Item no.

7798-015-8

7798-015-9

7798-015-10

02

**Disposable gloves „NITRIL“**

## ► Technical specifications

- nitrile
- powder free
- non-sterile
- manufactured according to EN 455
- 100 pieces a box



02

Item no.

7798-016-8

7798-016-9

7798-016-10

01

**Disposable gloves Nitril black**► **Product description**

- free of silicone, powder and latex
- material thickness: 0,08mm
- 100 pieces in carton
- very good fit
- good sense of touch
- for protection against chemicals,
- very light acids and alkalis
- food approval
- tear-resistant
- can be worn on both sides



Item no.	Model
7797-029-8	Size M
7797-029-9	Size L
7797-029-10	Size XL

02

**Nitrile disposable gloves „HIGH RISK“**► **Product description**

- disposable nitrile glove
- 50 pieces Box
- premium quality
- Colour: blue
- unpowdered
- Length: approx. 30 cm
- thickness: 0,2 mm
- twice as strong as a conventional nitrile disposable glove
- extremely resilient
- chemical protection
- excellent chemical resistance and puncture resistance
- substantially more resistant to punctures and abrasion than latex or vinyl
- food approval
- latex-free
- silicone-free
- good fit
- particularly safe and tear-resistant
- secure grip due to slightly roughened surface



Item no.	Model
7797-031-8	Size M
7797-031-9	Size L
7797-031-10	Size XL
7797-031-11	Size XXL
7797-031-12	Size XXXL



03

**Disposable glove „GRIP“**► **Technical specifications**

- non-sterile
- rolled edge
- powder-free
- scale surface for particularly strong grip on wet and dry surfaces
- excellent fit
- particularly sturdy
- for food contact
- can be worn on both sides
- AQL 1.5
- Colour: orange
- Thickness: approx. 0.26 mm (finger), approx. 0.15 mm (palm)
- Quantity per box: 100 pieces



Item no.
7798-019-8
7798-019-9
7798-019-10
7798-019-11

01

**Welding protection glove „FIRE“**

- ▶ Technical specifications
- 5-finger welding glove
- full/split leather combined
- split cuff
- length: 35 cm
- certification
- EN 388, EN 12477, TÜV/GS



Item no.  
7798-012-10

03

**Working gloves „COW“**

- ▶ Technical specifications
- split leather glove
- Leather thickness: 1,0mm
- double seams
- palm lining
- white back and canvas cuff
- EN Standards / Performance values
- EN 388
- Category 2
- Power value 2131



Item no.  
7798-014-10

02

**Working gloves „HIDE“**

- ▶ Technical specifications
- cowhide full leather glove
- ankle protection
- rubberized cuff
- palm lining
- tested by TÜV Rheinland
- EN Standards / Performance values:
- EN 420 + EN 388
- Kat. II
- Power value 3123



Item no.  
7798-013-10

04

**Mechanic gloves „NAPPA“**

- ▶ Technical specifications
- very supple and hard-wearing nappa leather
- breathable textile backing
- unlined for the best possible fingertip feeling
- Velcro wrist closure
- perfect fit and hold due to Velcro wrist closure
- only conditionally suitable for wet conditions
- for medium to heavy mechanical loads
- good resistance to abrasion and cuts
- Manufacturing according to EN 420, EN 388 CAT 2
- Safety values: 2111



Item no.  
7798-023-8  
7798-023-9  
7798-023-10  
7798-023-11

01

**Pro-Vision safety glasses**

with compound glass

▶ Item no. 4695-006-500

▶ Product description

- The stylish, shatterproof glasses protect the eyes when working.



01

02

**Safety glasses Astrospec**

Polycarbonate lens

▶ Item no. 7794-002-0

▶ Item no. 7794-002-01

▶ Spare lenses

▶ Product description

- Anti-mist on the inside
- Scratch-resistant on the outside
- Soft components on the arms for extra wear comfort
- Excellent fit thanks to adjustable arm length
- Easy-to-change lenses
- Highest UV protection (100%)



02

03

**Safety glasses X-one**

Anti-scratch coating

▶ Item no. 7794-001-0

▶ Product description

- Scratch-resistant coating
- Lightweight glasses (28g)
- Stylish design
- Highest UV protection (100%)
- Comfort fit in spite of simple arms



03

01

**Full-vision goggles**

with wide rubber band and clear polycarbonate lens

▶ Item no. 7794-006-0

▶ Product description

- with indirect ventilation
- extremely large field of view
- also suitable for spectacle wearers
- non-fogging polycarbonate lens
- high wearing comfort
- adjustable headband
- replaceable disc
- unrestricted page perception
- Standards: Category II EN 166 BT N



04

05

**Nylon goggles**

with compound glass

▶ Item no. 4695-006-433



05

06

**Panorama full vision goggles**

PC transparent lens, 100% UV protection

▶ Item no. 7794-003-0

▶ Item no. 7794-003-01

▶ Spare lenses

▶ Product description

- Ergonomically designed full view goggles
- Anti-scratch coating on the outside
- Anti-mist coating on the inside
- Body: grey transparent
- Headband: Uvex, 25 mm
- Highest UV protection (100%)
- Unlimited side vision



06



01  
**PRO automatic helmet**  
Carbon look

► Item no. 4695-007-100

► Product description

- Anti-glare dark slide: 1/1/1/2
- Scale numbers DIN 4/5-8 and 9-13
- WIG-suitable from 5 amperes
- Grinding mode
- Large viewing field 53 x 100mm
- Four mutually independent sensors
- Smoothly adjustable
- Power supply using solar cell & replaceable support battery
- Standard attached pane 90 x 110mm
- Interchangeable replacement attached pane, art. no. 4695-007-110



02  
**Viewing pane 90 x 110 mm**  
for (4695-007-100)

► Item no. 4695-007-110



02

03

**Hand shield**

► Product description

- Partly heat-resistant hand shield without attached pane
- The clear and green attached panes are interchangeable

Item no.	Model
4695-006-440	Shield (without glass)
4695-006-442	Cover lenses clear
4695-006-446	Green lens



03

04

**Folding welder goggles**

► Product description

- These goggles complete with flip-up front provide a clear view when welding.

Item no.	Model
4695-006-461	Spare lenses non shattering
4695-006-465	Spare lenses athermal



04

05

**Schutzschild**

► Produktbeschreibung

- Kopfhaltung aus Polypropylen
- extrem hohe Schlagfestigkeit und Chemiekalienfestigkeit

Art.Nr.	Ausführung
7936-000-000	Scheibe
7907-002-000	Kopfhaltung



05

01

**Gehörschutzstöpselspender**

schwarz, leer

▶ Art.-Nr. 7695-006-500

▶ Produktbeschreibung

- inkl. Befestigungsmaterial
- ohne Inhalt
- passende Artikel 7695-006-501 und 7695-006-502



01



02

02

**Earplugs**

300 pairs

▶ Item no. 7695-006-501

▶ Product description

- us Soft PU
- loose in large polybag
- conical shape
- high wearing comfort
- permanent remodelling
- excellent insulation values
- EN 352-2
- SNR 34 db(A)
- H 33 db(A)
- M 31 db(A)
- L 28 db(A)

03

**Earplugs**

50 pairs

▶ Item no. 7695-006-502



03

04

**Hearing protection plug**

100 pairs

▶ Item no. 7695-006-600

▶ Product description

- No strap
- Hygienically packed in pairs



04

05

**Hearing protection**

up to 25dB

▶ Item no. 7126-003-000

▶ Product description

- Extremely light and comfortable to wear
- Special plastic headband
- Very soft ear cups
- Gentle contact pressure
- SNR value 25 dB



05

06

**Clip ear protection**

▶ Item no. 7695-006-610

▶ ear muffs

▶ Item no. 7695-006-611

▶ spare plugs

▶ Product description

- The handy headband ear defenders are ideal for rapid use in most noise situations
- The oval pads provide an improved fit on the auditory canal

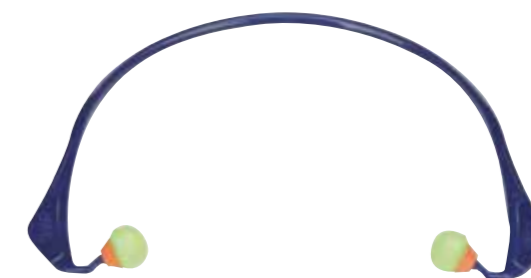

06



01

**LED AKKU workshop light SL550**

incl. USB charging cable

► Item no. 7982-70-10

## ► Technical specifications

- robust and splash-proof plastic housing with rubberized grip surface
- Main light with two light functions (50% | 100% light output)
- Light intensity: 550 Lumen
- Additional lamp on the lamp head
- Lighting duration: Main light 100% 2.5 hours | 50% 5.5 hours
- Lighting time: Additional light 10 hrs.
- Mounting: Holding magnet on the underside of the handle
- Additional functions: Lamp handle 120° rotatable, can be locked in 5 positions for flexible light alignment, battery indicator via 3 green LEDs
- Battery: fixed Li-Ion battery pack (3.7V | 2600mA)
- Charging option: via Micro USB socket, optionally via AC/DC power supply (110V-240V) or car adapter (12-24V)
- Scope of delivery: USB charging cable 150 cm, instruction manual
- Weight: 350 g
- Total length: 34 cm
- Length of LED lamps: 12 cm
- splash-proof IP 54



01

02

**LED workshop light UL 200**

incl. USB charging cable

► Item no. 7982-70-40

## ► Technical specifications

- Additional lamp on the lamp head
- robust and splash-proof plastic housing
- 180° rotatable, 7-stage lockable lamp handle for flexible light alignment
- Holding magnet on the underside of the handle and on the back of the lamp
- fixed Li-Ion battery pack (3.7V | 2600mA)
- Charging option via Micro USB socket
- Charge control display via 1 green/red LED
- Switch on the back of the lamp
- Charging socket on the side of the lamp
- 360° fold-out and rotatable holding hook

Scope of delivery:

- USB charging cable 250 cm
- instruction manual



02

03

**Workshop light LED mini Light ML220**

incl. USB charging cable

► Item no. 7982-70-30

## ► Technical specifications

- robust plastic housing with rubberized grip surface
- 340° rotatable, twelve-stage lockable lamp shackle for flexible light alignment
- strong holding magnet on the underside of the lamp bracket
- pull-out, 360° rotatable hook on the upper side of the housing
- integrated belt clip on the back of the housing
- Luminaire with two light functions (100% / 50% light output)
- fixed Li-Ion battery pack (3.7V / 1550mAh)
- Charging via USB power supply (110V-240V) or USB car adapter (12-24V)
- Charge control display via coloured LED on the rear of the lamp
- Light output: 220 lumen

Scope of delivery:

- USB charging cable 250 cm
- instruction manual



03



01

**LED professional workshop light WL 440**

incl. USB charging cable

► Item no. 7982-70-50

## ► Technical specifications

- Lumen at 0.5m distance: Main lamp: 440/ 280 lumen - Additional lamp: 180 lumen
- 180° rotatable handle
- Lamp handle lockable in eight levels
- robust and splash-proof plastic housing
- rubber grip surface
- modern LED technology
- Effective lighting duration: Main light: up to 6 h - Additional light: approx. 9 h
- Charging time: approx. 4 h
- Mounting options for the lamp:
- 2x fold-out, 360° rotatable hooks
- 2x holding magnets on back side
- 1x magnet on underside
- incl. Micro USB charging cable 1.5m (optionally chargeable via USB AC charger or car adapter, not included)
- Weight: 340 g
- Dimensions: 266 x 48 x 32 mm



01

02

**LED professional inspection light NF500R**

incl. USB charging cable

► Item no. 7982-70-60

## ► Technical specifications

- robust plastic housing
- rubber grip surface
- modern LED technology
- effective light duration: main light: approx. 2.5 h - additional light: approx. 5 h
- Charging time: approx. 3.5 h
- Mounting options for the lamp:
- 360° rotatable hook on the upper side of the housing
- Magnet on the back of the housing
- incl. Micro USB charging cable 1.5m (optionally chargeable via USB AC charger or car adapter, not included)
- Weight: 190 g
- Dimensions: 280 x 40 x 27 mm



02

03

**LED battery-powered spotlight BL1000**

incl. AC power supply 1A with charging cable and holding magnet

► Item no. 7982-70-70

## ► Technical specifications

- robust and splash-proof plastic housing with rubberized protective edge
- CRI function for detail and polishing work
- Luminaire with three light functions (20% / 45% / 100% light output)
- Light intensity: 1000 Lumen
- Operating time: 9 hrs.
- Mounting: magnet, hole for tripod in foot part
- Additional functions: Swivel handle
- Battery: fixed Li-Ion battery pack (11.1V | 2200mAh)
- Charging possibility: via supplied AC power supply 1A
- Scope of delivery: AC power supply 1A, charging cable and magnet
- Weight: 720 g
- Dimensions: 209 x 190 x 73 mm
- Total diameter LED: 2 cm
- splash-proof IP 65



03

04

**LED AKKU workshop light PL120**

incl. USB charging cable

► Item no. 7982-70-20

## ► Technical specifications

- robust and splash-proof plastic housing with rubberized grip surface
- small additional light at the lamp head
- Light intensity: 120 Lumen
- Lighting duration: Main light 3.5 hrs.
- Lighting time: additional light 5 hrs.
- Mounting: Retaining clip and magnet
- Battery: fixed Li-Ion battery pack (3.7V / 750mAh)
- Charging option: via Micro USB socket, optionally via AC/DC power supply (110V-240V) or car adapter (12-24V)
- Scope of delivery: USB charging cable 150 cm, instruction manual
- Total length: 17 cm
- Length of LED lamps: 3 cm
- splash-proof



04

01

**LED professional workshop light ILC 350**

incl. USB charging cable

► Item no. 7982-70-100

► Technical specifications

- LEDs: 12x 0.5W LEDs (6W)
- luminous flux: 305 lm
- Illumination angle: Wide angle
- Cable length: 5 meters
- Protection class: IP20 / IK07
- Weight: 550g
- Housing material: ABS & PC
- length: 324,9mm
- Light range 23 meters
- Shockproof up to 1m height of fall
- Holding hook 360° rotatable
- integrated magnet on the back
- power button



01

03

**LED engine compartment light MRL 1000**

incl. USB charging cable

► Item no. 7982-70-130

► Technical specifications

- LEDs: 32x SMD LEDs
- luminous flux: 500-1000 lm
- lighting duration: 3-6h
- Protective functions: Deep Discharge Protection
- Battery pack: Li-Ion 3.7V with 4.400 mAh
- Housing material: aluminium
- Protection class: IP65 & IK07
- Weight: 805g with battery
- length: 1153mm
- Light range: 22-31m
- Dual energy supply
- 2 hooks (360° rotatable)
- various switch functions



03

02

**LED professional inspection light ILF 200**

incl. USB charging cable

► Item no. 7982-70-110

► Technical specifications

- Main LED: 2 Watt COB LED
- Additional LED: 3 Watt SMD LED
- luminous flux: 70-230 lm
- lighting duration: 1,5-4h
- Protective functions: Depth Charge Protection
- Battery pack: 3.7V Li-Po 700mAh
- Protection class: IP20
- length: 173,9mm
- Light range: 10-25m
- 1 retaining clip on the back
- rotating base with magnet
- various switch functions



02

04

**Battery lamp set**

incl. USB charging cable

► Item no. 7982-70-140

► Technical specifications

- lumen at 0.5 m distance: main light: 440/ 280 lumen - additional light: 180 lumen
- handle can be rotated by 180
- Lamp handle lockable in eight steps
- robust and splash-proof plastic housing
- rubberised handle
- modern LED technology
- effective burning time: main light: up to 6 h - additional light: approx. 9 h
- Charging time: approx. 4 h
- Fastening possibilities of the lamp: 2x fold-out, 360° rotatable hooks,
- 2x holding magnets on the back, 1x magnet on the bottom
- Weight: 340 g
- Dimensions: 266 x 48 x 32 mm



04

01

**LED Headlamp HL 260S**

▶ Item no. 7982-70-90

▶ Technical specifications

- Sensor and key function
- Control through gesture control
- adjustable head
- 2 light levels
- 260 lumens
- 110 lux
- shockproof
- splash-proof
- rubberized border
- Dimensions: 78,5 x 48 x 42 mm
- Weight: 110 g
- Light duration: up to 5.5 hours
- Charging time: 2.5 hrs
- Scope of delivery:
- Light
- Headband
- Micro USB cable
- Multilingual user manual



01

02

**Telescopic mount Duo for BL series**

▶ Item no. 7982-70-60

▶ Technical specifications

- Height: 1,73m
- Weight: 2900g
- Material: aluminium



02

01

**Flashlight attachment**

- ▶ Item no. 7982-70-143
- ▶ Technical specifications
  - Rotary contact element to base unit
  - Swivel joint (180° pivoting / 360° rotating)
  - Focusable lamp head



01

**NEW**

02

**Workshop light attachment Slim**

- ▶ Item no. 7982-70-144
- ▶ Technical specifications
  - Rotary contact element to base unit
  - Swivel joint (180° pivoting / 360° rotating)
  - Work light
  - Searchlight



02

**NEW**

03

**Battery handle**

- ▶ Item no. 7982-70-141
- ▶ Technical specifications
  - Interlocking
  - power button
  - Micro USB charging jack with rubber cover
  - Charge and capacity indicator
  - Integrated magnet
  - Integrated hook 360° rotatable



03

**NEW**

04

**Inspection light attachment Flex**

- ▶ Item no. 7982-70-142
- ▶ Technical specifications
  - Rotary contact element to base unit
  - Flexible lamp neck
  - Focusable lamp head with integrated magnet



04

**NEW**

05

**AC power supply USB**

- ▶ Item no. 7982-70-001
- ▶ Technical specifications
  - Input: 100-240V AC 50/60 HZ max. 0,3A
  - Output: 5V-max. 1000mA



05

**NEW**

06

**Battery handle**

- ▶ Item no. 7982-70-002
- ▶ Technical specifications
  - Input: 12V / 24V - 550mA



06

**NEW**

03

**LED Profi-Kugelschreiberleuchte PL20**

inkl. 2 x AAA Micro Batterien

► Item no. 7982-70-80

## ► Technical specifications

- modern LED technology
- incl. 2x AAA batteries, hand loop and belt clip
- Weight: 64 g (including batteries)
- Dimensions: 142 x 16 mm



04

**LED inspection lamp**

For checking brake pads

► Item no. 3721-503

## ► Product description

- Extra reinforced clip (non-slip)
- Aluminium housing
- Light source: 5 mm LED
- Length: 125 mm / ø of head 12 mm
- Includes batteries (2x AAA, micro)
- Constant light yield
- With instantaneous clip connection

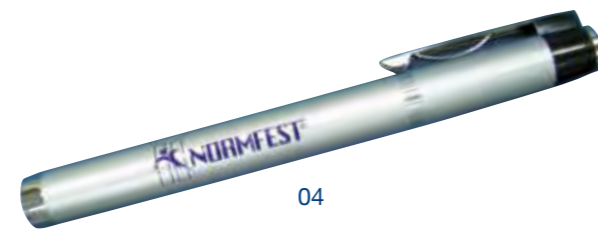

01

**Inspection lamp for dent repairs**

Incl. suction base

► Item no. 8714-610

## ► Product description

- Flexible use
- Can also be used as a hand lamp via the detachable flexible arm
- Paint-protecting 120 mm-diameter suction foot
- 300 mm long flexible arm with star handle
- Protects eyes thanks to prismatic protective glass

- 220/240 Volt with automatic switch-off
- 50/60 Hz
- 900 Lumen
- 210 mm light length
- Width: 38.5 mm
- Length: 65 mm
- 11 Watt fluorescent lamp
- 5m supply cable



05

**Hazardous, explosion-proof flashlight**

Atex, 200 lumen

► Item no. 7981-70-11

## ► Technical specifications

- waterproof construction
- made of almost unbreakable polycarbonate glass
- intrinsically safe for use in hazardous environments
- shock- and impact-resistant polycarbonate housing
- Temperature resistant up to 135 °C
- Operating time: up to 50 hours
- Light source: High power LED
- Luminous intensity: 200 lumen (two brightness levels)
- Luminous flux: 200 Lumen
- headlight range: 172m
- Protection class: Ex ia IIC T4 Ga
- Power supply: 4 AA batteries
- IP protection class: IP67
- Net weight: 214 g
- Dimensions: (LxHxW) 170 x 50 x 30 mm
- weight: 0,21 kg





01

**Disposable hand lamp**

8 W

► Item no. 7981-66

► Product description

- 8 W, 220-240 V
- Anti-roll hexagonal shape
- Swivel hanging hook
- UV, oil and petroleum resistant
- 220-230 V, 50-60 Hz



01

**Suitable for organic binding agent for oils and chemicals**

Oil-Catcher Premium

- ▶ Item no. 7874-150
- ▶ Contents: 50 litres
- ▶ Packing unit: 1

▶ **Technical specifications**

- Fast absorption of oils, chemicals, fuels, paints, and much more.
- Basis: Natural fibre
- pH value: 3.8
- Universally applicable
- For indoor and outdoor use
- Can be used in all conditions
- Reusable until complete saturation
- Non-toxic to humans, animals and the environment
- Can be used on any surface
- Economical and easy to use
- Easy to dispose of
- No long-term contamination of soils, water or aquifers
- No long-term physical or visual effect on the environment

01



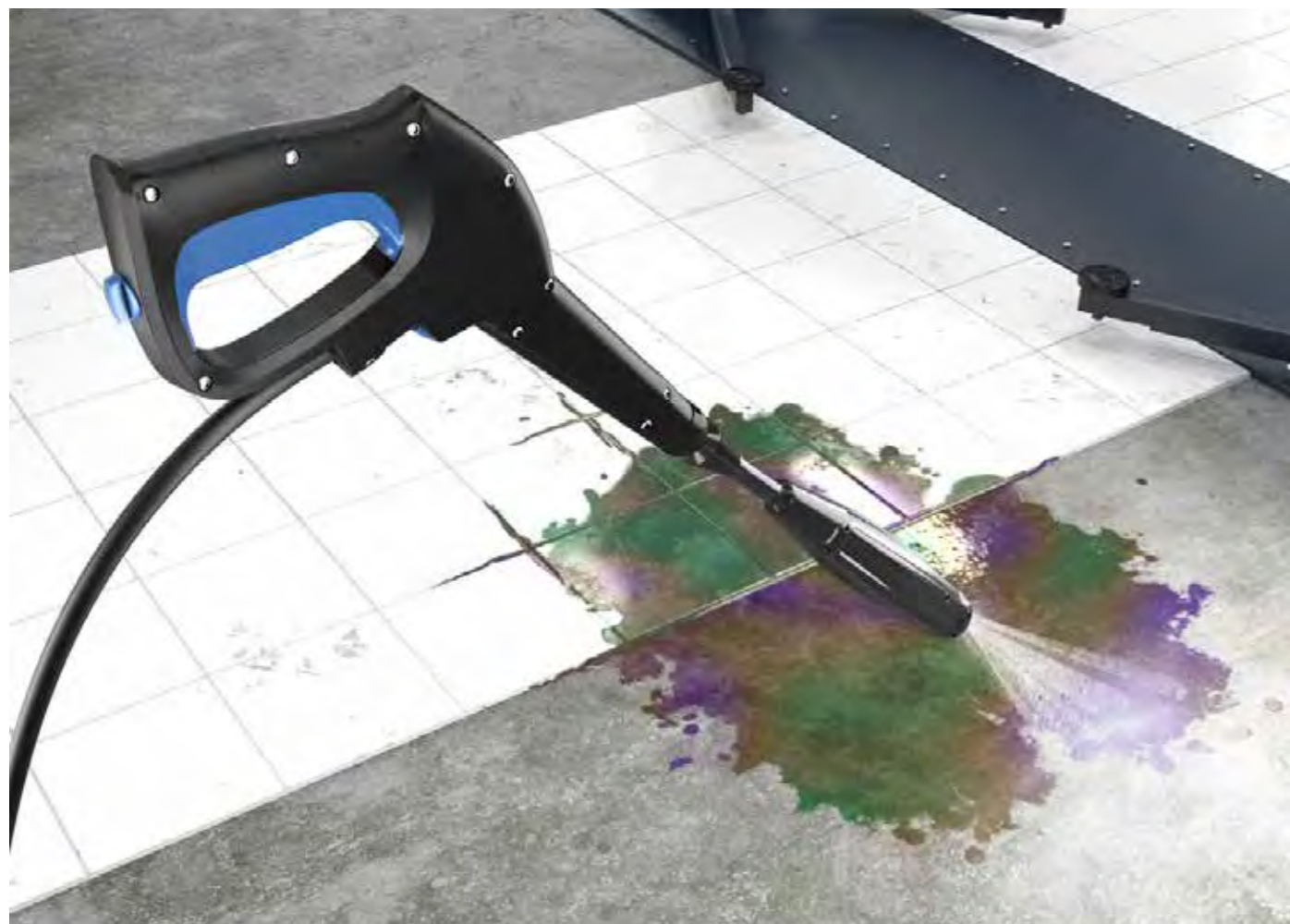

01

**Bio Star Extrem**

Universal garage cleaner

- ▶ Item no. 2897-270-5
- ▶ Contents:
- ▶ Packing unit: 1

- ▶ Item no. 2897-270-30
- ▶ Contents:
- ▶ Packing unit: 1

▶ **Product description**

- highly active cleaning concentrate
- for the removal of oils, greases, soot and heavy soiling of all kinds
- for hall and workshop floors, washrooms and workshops, wall and floor tiles, beams, ceilings, gates and tarpaulins
- label-free from the Protect series
- AOX & solvent-free
- NTA free
- biodegradable
- pH value 11.2
- Mixing ratio 1:5 to 1:30



02

**Workshop cleaner**

Bio-Star

- ▶ Item no. 2897-250-30
- ▶ Contents: 30 litre
- ▶ Packing unit: 1

- ▶ Item no. 2897-250-5
- ▶ Contents: 5 litres
- ▶ Packing unit: 1

▶ **Product description**

- Highly active concentrate for cold and high-pressure cleaning
- Suitable for cleaning heavily soiled factory floors, walls and floor tiles
- Removes lubricating oil, grease, soot, pigments, resin and tar
- High-pressure cleaner mixing ratio: 1:3 to 1:5
- Mixing ratio for manual use: 1:1 to 1:5
- pH value: 13.2 (alkaline)
- AOX-free



03

**Oil-stain remover**

Oel-Ex

- ▶ Item no. 2897-341
- ▶ Contents: 400 ml
- ▶ Packing unit: 12

▶ **Product description**

- Effective aid against oil stains and old oil stains
- Removes oil stains from all absorbent and non-absorbent substrates, such as stone, natural stone and concrete blocks, clay and pumice, screed, clinker and ceramic
- Can also be used on carpets and textile flooring
- Colour: White
- Important: Do not use on bitumen, asphalt or slate!



01

02

03



01  
**Normfest-style batteries**  
Power, PU: 40 pieces

Item no.	Description	Voltage
3722-71	Mignon AA	1.5 V



01

02  
**Normfest-style batteries**  
Power, PU: 40 pieces

Item no.	Description	Voltage
3722-72	Micro AAA	1.5 V



02

03  
**High-energy batteries**

Item no.	Voltage	Model	Figure
3722-01	1.5 volts	Mono D	1
3722-02	1.5 volts	Baby C	2
3722-03	1.5 volts	Mignon AA	3
3722-04	1.5 volts	Micro AAA	4
3722-05	9.0 volts	Block E	5

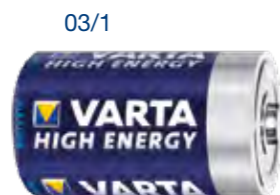

03/2



03/4



03/5



Item no.	Voltage	Model	Figure
3722-24	12 volts	A 23, MN 21	1
3722-29	1.5 volts	LR 1, 4001	2

04/1



04/2



05  
**Rechargeable batteries**

Item no.	Model	Figure
3722-40	800 mAh Micro AAA	1
3722-41	2100 mAh Mignon AA	2

05/1



05/2



06  
**Button cell batteries**

Item no.	Description	Voltage	Item no.	Description	Voltage
3722-42			3722-26	CR 1616	3 volts
3722-20	CR 2025	3 volts	3722-27	CR 1220	3 volts
3722-21	CR 2032	3 volts	3722-30	CR 1632	3 volts
3722-22	625 A, LR 9	1.5 volts	3722-31	V13 GA, LR 44	1.5 volts
3722-23	CR 2016	3 volts	3722-32	CR 2450	3 volts
3722-25	CR 1620	3 volts	3722-33	CR 1/3 N	3 volts
3722-27	CR 1220	3 Volt			



06

07  
**Assortment of button cells**

- Item no. 1957-580
- Contents: 75 parts
- 10 x CR1220 3V (art. no. 3722-27)
- 10 x CR1616 3V (art. no. 3722-26)
- 10 x CR1620 3V (art. no. 3722-25)
- 10 x CR1632 3V (art. no. 3722-30)
- 10 x CR2016 3V (art. no. 3722-23)
- 10 x CR2025 3V (art. no. 3722-20)
- 10 x CR2032 3V (art. no. 3722-21)
- 5 x LR1 1.5V (4001) (art. no. 3722-29)



07



01  
**Cleaning paper roll**  
 2-ply, 1,000 tear-off sheets

- ▶ Item no. 7875-502
- ▶ 22 x 36 cm embossed, fully coated
  
- ▶ Item no. 7875-503
- ▶ 36 x 38 cm embossed, fully coated

- ▶ Product description
- Colour: blue
- PU: 2



01

02  
**Cleaning paper roll**  
 3-ply, 1,000 tear-off sheets

- ▶ Item no. 7875-504
- ▶ 38 x 36 cm

- ▶ Product description
- Layers: 3
- Tear-off sheets: 1,000 / roll
- Sheet size: 38 x 36 cm
- Roll diameter: 29cm
- Roll length: 350m
- Colour: blue
- embossed, fully bonded
- Packaging unit: 2 pieces



02

03  
**Rolls of lint-free fleece cloth**  
 500 tear-off sheets per roll, 38x30 cm

- ▶ Item no. 7875-505
- ▶ 38x30 cm

- ▶ Technical specifications
- Lint free
- Can be used wet and dry
- Biodegradable
- Components: 55% sawdust – 45% polyester (no binding agents)
- Colour: Turquoise
- Solvent resistant
- Highly absorbent
- Sold as a double roll
- 500 tear-off sheets per roll
- Sheet height: 38 cm
- Sheet width: 30 cm



03

04  
**Fibre fleece cleaning cloth**  
 perforated, 400 pcs. to tear off

- ▶ Item no. 7875-5
- ▶ 29 x 39 cm

- ▶ Product description
- Very absorbent
- High cotton content
- Can be wrung out
- Tear resistant
- Resistant to most solvents
- 2 rolls per pack
- 400 cloths per roll
- 29 x 38 cm
- Perforated for easy tearing
- Textile cloths (70% cotton, 15% synthetic fibres, 15% PP)



04

01

**Fleece roll**

perforated, 400 pcs. to tear off

- ▶ Item no. 7875-500
- ▶ 29 x 38 cm

▶ Product description

- Colour: White
- Highly absorbent
- Excellent tear and wear strength, wet or dry,
- Washable and wringable
- Solvent-resistant
- Silicone-free
- Food safe
- Perforated
- 400 perforations
- Roll length: 152m



01

02

**Cellulose pads roll**

2-ply, 750 pcs. to tear off

- ▶ Item no. 7875-1
- ▶ 27 x 40 cm, PU: 2

▶ Product description

- Roll length: 255 m
- Colour: white
- Very absorbent
- 2-ply
- Dimensions: 23.5 x 34 cm



02

03

**Workshop refuse bags**

120 litres

- ▶ Item no. 7875-908
- ▶ Colour: blue

▶ Product description

- 100 pieces on each roll
- 60 µm



03

04

**Chrome wall mount**

Max. roll width 75 cm

- ▶ Item no. 7875-901

▶ Product description

- For 3 compact rolls, max. roll width 75 cm
- Seat covers, compact rolls and rubbish bags
- H x W x D: 70 x 76 x 24 cm

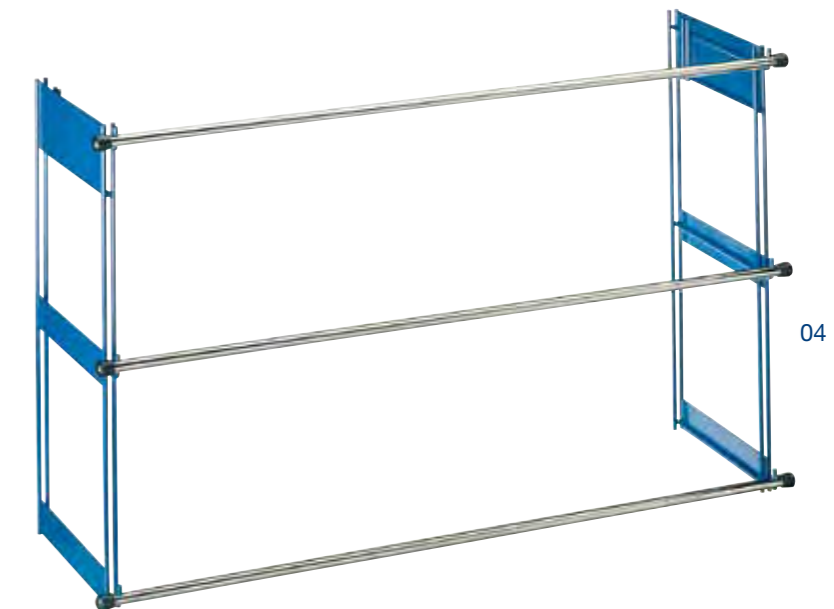

04

05

**Cleaning paper floor stand**

max. roll width 40 cm

- ▶ Item no. 7875-3



05

06

**Chrome dispenser for cleaning paper**

max. roll width 40 cm

- ▶ Item no. 7875-2

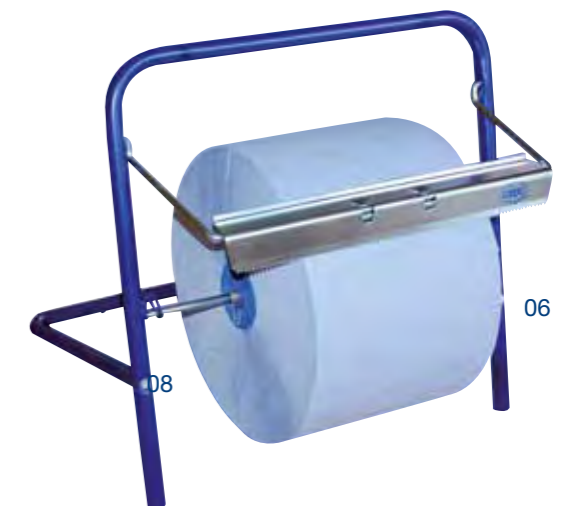

06

08

01

**Protective seat covers**

- ▶ Item no. 7875-902
- ▶ Roll each with 500 pcs.

- ▶ Item no. 7875-904
- ▶ Roll each with 100 pcs.

▶ **Product description**

- Dimensions: 82 cm x 130 cm
- Strength: 13my
- Roll of 500
- Perforated
- Also approved for seats with side airbags



01

02

**Protective seat covers**

Made from imitation leather

- ▶ Item no. 7875-920-000

▶ **Product description**

- Approved for seats with airbag functions
- Imitation leather
- Washable to 40°C
- Not suitable for pale leather seats!



02

03

**Protective seat cover, anti-static**

- ▶ Item no. 7875-905
- ▶ Roll each with 250 pcs.

▶ **Product description**

- Dimensions: 840 x 1400mm
- Permanently antistatic
- Roll of 250
- Approved for Daimlers



03

04

**Compact roll 5 in 1**

- ▶ Item no. 7875-911
- ▶ 250 sets on each roll

▶ **Product description**

- Seat cover PE white 840 x 1,400 mm
- Foot mat PE white non-slip 550 x 590 mm
- Steering wheel cover PE blue 490 x 150 mm
- With punched holes, gear lever and handbrake cover



04

05

**One-way steering wheel protector for trucks**

- ▶ Item no. 7410-003-019

▶ **Technical specifications**

- PE film with elastic band
- diameter: 55 cm
- PU: 250 pieces
- thickness: 20μ
- Colour: white



05

01

**Disposable foot mats**

- ▶ Item no. 7875-510
- ▶ Roll each with 500 pcs.

- ▶ Product description
- Colour: white
- 70g/m<sup>2</sup>



01

02

**Duo foot mats**

Disposable, perforated

- ▶ Item no. 7875-511
- ▶ 500 pcs. in a carton

- ▶ Product description
- No leakage of liquids and oils
- Very high tensile strength due to laminated, anti-static film
- 38 x 50 cm
- Paper: 70 g grey



02

03

**Steering wheel covers roll**

- ▶ Item no. 7875-900
- ▶ Steering wheel covers roll
- ▶ Item no. 7875-900-01
- ▶ Handle for steering wheel cover roll

- ▶ Product description
- Length: 300 m
- Width: 14 cm
- Core inner diam.: 3.8 cm



03

04

**Mudguard cover**

Made from polyester

- ▶ Item no. 7875-921-8

- ▶ Product description
- With magnet
- 100 cm x 65 cm
- With two tool pockets



04

05

**Mudguard cover**

Made from imitation leather

- ▶ Item no. 7875-921-9

- ▶ Product description
- With magnet
- 100 cm x 65 cm



05

06

**High temperature protective blanket**

- ▶ Item no. 4982-001

- ▶ Product description
- Resistant to sparks and spatter
- Material: Glass filament fabric (flame-resistant, non-combustible)
- Weight: 3.5 kg
- Dimensions: 160 x 230 cm with fastening straps
- Thickness: 0.5 mm
- Heat resistant: up 750°C
- Elongation at break: 3%



06

07

**Protective welding blanket**

- ▶ Item no. 4982-000

- ▶ Product description
- Dimensions: 229 x 188.5 cm
- Heat resistant: up 700°C
- Max. radiation temperature: up to 1,000°C
- Abrasion and knick-proof



07



01

**Electronic multifunctional battery charger**

Telwin Doctor Charge 50

► Item no. 7771-12-30

## ► Product description

- "Pulse Tronic" automatic charging and trickle-charging
- Corresponds to the current-voltage characteristic (IUoU characteristic)
- Battery test to identify the voltage at the terminals, for example, or the starting capability (CCA) and for checking the functionality of the vehicle's own
- "Pulse Tronic" automatic charging and trickle-charging
- Corresponds to the current-voltage characteristic (IUoU characteristic)
- Battery test to identify the voltage at the terminals, for example, or the starting capability (CCA) and for checking the functionality of the vehicle's own
- alternator
- Revival and restoration of batteries, even exhausted ones
- Protection of on-board electronics when changing batteries, during diagnostics and in showroom mode
- Auxiliary start
- Effective charging current: 45 A conventional charging current (according to EU Regulation): 40 A
- Long power cable: 1.5m
- Long charging cable: 3m



01



02

**Startbooster with multifunction tester**

Startzilla 3024 12/24V of the brand Telwin

► Item no. 7771-30-24

## ► Technical specifications

- 12V Startbooster & Multifunction Tester for AC Alternators
- compact and lightweight
- with power bank function
- strong LED light in red and white
- user-friendly LCD display
- has all protection functions
- Supplied with starter cable and power supply unit
- ICE start function for reliable starting of 12/24V vehicles in extremely cold weather of -20°C
- Starting voltage 12/24V
- max. starting current 1500A
- USB output voltage 5V
- USB output voltage 2.1A
- DC output voltage 12/16 & 19V
- powerful lithium battery with 30000mAh
- Dimensions 28x10x18cm
- weight 3,3kg



02

01

**Battery conservation charger 12/24V**

Doctor Charge 130 230V of the brand Telwin

► Item no. 7771-12-130

► Technical specifications

- automatic charging and trickle charge of the batteries
- Repair of sulphated or heavily discharged batteries
- regulated voltage source for battery change, diagnostic activities or demonstration vehicles
- Start of vehicles
- battery test



01

02

**Automatic battery charger**

T-Charge 12 EVO of the brand Telwin

► Item no. 7771-6-12

► Technical specifications

- 6/12V automatic battery charger, conservation charger and test device
- suitable for all battery types
- coordinated charging programs
- Pulse Tronic
- Pulse method for repairing sulfated batteries
- Test function for vehicle alternator and batteries
- Supply function for power supply during battery replacement
- Cold function for high performance charging at sub-zero temperatures
- User-friendly LCD display
- has all protection functions
- Protection against overload, short circuit and reverse polarity
- Connection cable with charging pliers & eyelets included
- max. unit rated power: 70 Ah
- single-phase mains voltage: 230 V
- Switching levels: Automatic
- Mains frequency: 50 - 60 Hz
- dimensions: 17 - 6,5 - 3,5 cm
- Power consumption during charging : 55 KW
- weight: 0,6 kg
- Charging voltage: 6 / 12 V
- effective charging current: 1 / 4 A



02

03

**Battery charging clips**

Item no.	Model
7771-16-200	Red 200 A PCV
7771-16-201	Black 200 A PCV
7771-35-600	Red 600 A CV
7771-35-601	Black 600 A CV



03

04

**Overvoltage protection**

► Item no. 4982-500

► Product description

- For commercial vehicles and cars
- Suppresses voltage peaks
- LED connection display
- No unclamping of battery when welding
- No reprogramming of radio, clock, etc.
- Significant time savings



04

05

**Battery jumper cables**

Item no.	Ø / mm <sup>2</sup>	Length	Figure
7771-16	16	3,0 m	2
7771-35	35 mit Überspannungsschutz	4,5 m	1
7771-50	50	5,0 m	2



05.1



05.2





01

**Parcel tape**

66 m x 50 mm

- ▶ Item no. 4985-049
- ▶ Colour: brown
  
- ▶ Item no. 4985-050
- ▶ Colour: transparent



01

02

**Parcel tape**

„Caution - Glass“ warning tape

- ▶ Item no. 4985-052
  
- ▶ Product description
- For sealing and identification
- For fragile goods
- 66 m x 50 mm



02

03

**Packaging tape dispenser**

with brake

- ▶ Item no. 4985-051
  
- ▶ Product description
- For rolls up to 50 mm or 75 mm x 66 m

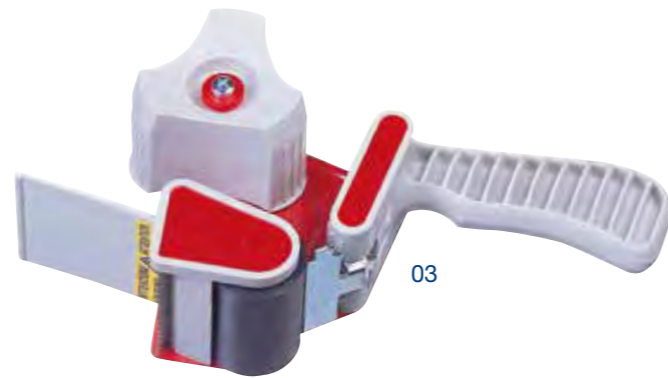

03

04

**Safety knife**

Martor quality

- ▶ Item no. 8715-57-604
  
- ▶ Item no. 8715-57-605
- ▶ Spare blades 10 pieces.



04



05

05

**Cutter knife**

incl. a spare blade

- |             |                         |
|-------------|-------------------------|
| Item no.    |                         |
| 8715-57-600 |                         |
| 8715-57-601 | Spare blades 10 pieces. |



06

06

**Cutter knife**

Material: sheet steel  
length: 13 cm, width: 1 cm  
blade width: 0.9 cm

- |             |                         |
|-------------|-------------------------|
| Item no.    |                         |
| 8715-57-602 |                         |
| 8715-57-603 | Spare blades 10 pieces. |

07

**Replacement saw blades**

For body saw (8696-1-60), optionally available

- ▶ Item no. 8696-112-551
- ▶ fine - 32 teeth, PU: 5
  
- ▶ Item no. 8696-112-552
- ▶ coarse - 24 teeth, PU: 5



07

08

**Replacement saw blades-SIG**

only for Wieländer and Schill saws

- ▶ Item no. 8696-112-554
- ▶ 24 teeth, PU: 5
  
- ▶ Item no. 8696-112-555
- ▶ 32 teeth, PU: 5



08

09

**Replacement saw blades**

For body saw (8696-1-60), optionally available

- ▶ Item no. 8696-113-71
- ▶ Sheet metal up to 2 mm (32 teeth), PU: 5
  
- ▶ Item no. 8696-113-72
- ▶ Steel/aluminium up to 5 mm (24 teeth), PU: 5



09

01

**Flat brush**

- ▶ Item no. 4693-1
- ▶ 1.0"
  
- ▶ Item no. 4693-15
- ▶ 1.5"
  
- ▶ Item no. 4693-2
- ▶ 2.0"



01

02

**Ring brush with plastic frame**

- ▶ Item no. 4693-02
- ▶ Size 2, Ø 1,5 cm
  
- ▶ Item no. 4693-04
- ▶ Size 4, Ø 2.0 cm
  
- ▶ Item no. 4693-06
- ▶ Size 6, Ø 2.5 cm
  
- ▶ Item no. 4693-08
- ▶ Size 8, Ø 3.0 cm
  
- ▶ Item no. 4693-010
- ▶ Size 10, Ø 3.5 cm



02

03

**Brush**

For body sealing compounds

- ▶ Item no. 4693-251-1



03

04

**Liquid flux brush**

Handle made of galvanised sheet metal

- ▶ Item no. 4693-500
  
- ▶ Product description
- Pale bristles
- Ø ferrule: 15 mm
- Length: 140 mm
- Height: 25 mm



04

05

**Repair brush**

Size 8

- ▶ Item no. 4693-311-5



05



07

**Flat brush**

Angled head, 1.5"

- ▶ Item no. 4693-450-15



07

08

**Brush**

for tyre mounting paste

- ▶ Item no. 4693-080-0



08

09

**Paint roller**

Content: 5 rolls

- ▶ Item no. 4693-999
  
- ▶ Product description
- Perfect, smooth primer surface thanks to macropores
- Width: approx. 10cm
- Diameter: approx. 3cm



09

01

**Brake calliper brush**

Smooth steel wire 0.35, particularly hard brush

- ▶ Item no. 8715-55-26
- ▶ For steel callipers
- ▶ Item no. 8715-55-27
- ▶ For aluminium callipers



01

02

**Steel wire brush**

- ▶ Item no. 4697-3
- ▶ 3-row
- ▶ Item no. 4697-4
- ▶ 4-row
- ▶ Item no. 4697-5
- ▶ 5-row



02

03

**Oil can**

White/Transparent, double-action brass pump, 0.2 litres

- ▶ Item no. 7713-000
- ▶ Product description
- Spray pipe, aluminium, curved



03

04

**Funnel set**

Oil, acid and petroleum resistant

- ▶ Item no. 2891-500-1
- ▶ Product description
- Resistant to oil, acid and fuel
- Versatile in use
- With handle
- Ø 50-75-100-120 mm



04

05

**Funnel with strainer**

Oil, acid and petroleum resistant

- ▶ Item no. 2891-500-5
- ▶ Product description
- With two-stage flexible outlet, detachable
- High overflow edge protects against splashes
- Interchangeable fine brass sieve
- Resistant to oil, acids and fuel



05

06

**Measuring cups**

oil-resistant and acidproof

- ▶ Item no. 2891-300-1
- ▶ 1 litre
- ▶ Item no. 2891-300-2
- ▶ 2 litres
- ▶ Item no. 2891-300-5
- ▶ 5 litres



06

07

**Measuring cups**

oil-resistant and acidproof

- ▶ Item no. 2891-400-05
- ▶ 0.5 litre, colour: orange
- ▶ Item no. 2891-400-1
- ▶ 1 litre
- ▶ Item no. 2891-400-2
- ▶ 2 litres
- ▶ Item no. 2891-400-3
- ▶ 3 litres
- ▶ Item no. 2891-400-5
- ▶ 5 litres



07

08

**Gooseneck**

for measuring cups with drain cocks

- ▶ Item no. 2891-400-050
- ▶ 0.5 litres
- ▶ Item no. 2891-400-10
- ▶ 1 litre
- ▶ Item no. 2891-400-20
- ▶ 2 litres
- ▶ Item no. 2891-400-30
- ▶ 3 litres



08

01

**Centre module**

3-compartment drawer module, lockable

▶ Item no. 7101-002-005

## ▶ Technical specifications

- Supporting force per drawer 8 kg
- Dimensions: H 444 x W 580 x D 340 mm
- RAL 7035 light grey



02

**Containers with 10 dividing panels**

Centre dividing module

▶ Item no. 7101-002-009

## ▶ Technical specifications

- Universal tub incl. 10 variable dividing panels
- Compartment width 87 mm
- Dimensions: H 444 x W 580 x D 340 mm
- RAL 7035 light grey



05

**Centre dividing module**

Universal shelves, double

▶ Item no. 7101-002-000

## ▶ Technical specifications

- Supporting force per shelf 20 kg
- Dimensions: H 444 x W 580 x D 340 mm
- RAL 7035 light grey



06

**Centre dividing module**

Base with perforated plate

▶ Item no. 7101-002-003

## ▶ Technical specifications

- Supporting force per shelf 20 kg
- Dimensions: H 444 x W 580 x D 340 mm
- RAL 7035 light grey

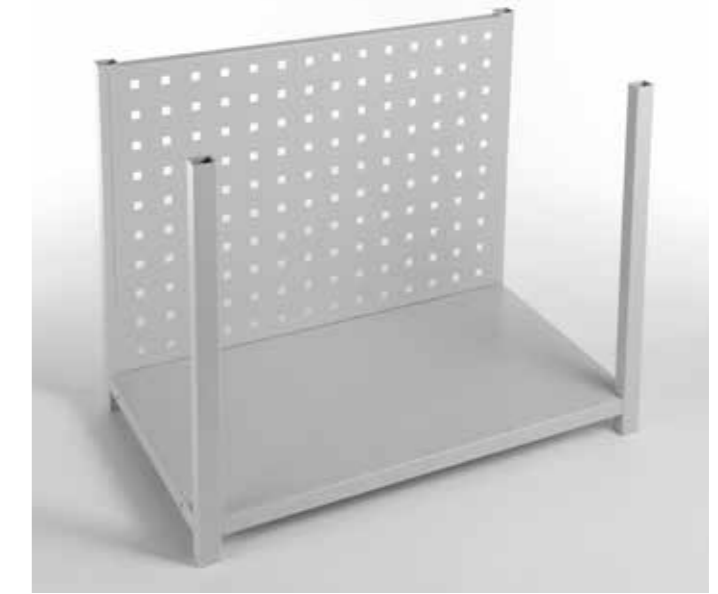

03

**Centre dividing module**

Can module, 1 compartment

▶ Item no. 7101-002-001

## ▶ Technical specifications

- with can compartment shelf, 6 compartments
- Dimensions: H 444 x W 580 x D 340 mm
- RAL 7035 light grey



04

**Floor corner module**

Corner module with base panel and a universal shelf

▶ Item no. 7101-004-002

## ▶ Technical specifications

- Supporting force per shelf 20 kg
- Dimensions: H 444 x W 623 x D 623 mm
- RAL 7035 Light grey



07

**Universal corner module**

Centre dividing module

▶ Item no. 7101-004-001

## ▶ Technical specifications

- Supporting force per shelf 20 kg
- Dimensions: H 444 x W 623 x D 623 mm
- RAL 7035 Light grey



08

**Centre dividing module**

Universal shelf, single

▶ Item no. 7101-002-007

## ▶ Technical specifications

- Supporting force per shelf 20 kg
- Dimensions: H 444 x W 580 x D 340 mm
- RAL 7035 light grey





01

**End module**

with universal compartment shelf

▶ Item no. 7101-003-000

▶ Technical specifications

- Supporting force per shelf 20 kg
- Dimensions: H 444 x W 580 x D 340 mm
- RAL 7035 light grey



02

**Bulk module**

Floor module

▶ Item no. 7101-001-004

▶ Technical specifications

- Universal tub incl. 10 variable dividing panels
- Compartment width 87 mm
- Dimensions: H 444 x W 580 x D 340 mm
- RAL 7035 light grey



03

**End module**

with universal compartment shelf

▶ Item no. 7101-004-000

▶ Technical specifications

- Supporting force per shelf 20 kg
- Dimensions: H 444 x W 580 x D 340 mm
- RAL 7035 Light grey



04

**with can compartment shelf, 6 compartments**

End module

▶ Item no. 7101-003-001

▶ Technical specifications

- Supporting force per shelf 20 kg
- Dimensions: H 444 x W 580 x D 340 mm
- RAL 7035 light grey



01

**Universal module 3-fold inclined**  
bottom module

▶ Item no. 7101-001-005

## ▶ Technical specifications

- Load capacity per shelf 20 kg
- Dimensions: H 544 x W 580 x D 340 mm
- RAL 7035 Light grey



02

**Floor module**  
with base panel without universal shelf

▶ Item no. 7101-001-006

## ▶ Technical specifications

- Supporting force per shelf 20 kg
- Dimensions: H 544 x W 580 x D 340 mm
- RAL 7035 light grey



05

**Drawer module 6-way lockable**  
Centre dividing module

▶ Item no. 7101-002-010

## ▶ Technical specifications

- Supporting force per drawer 8 kg
- Dimensions: H 444 x W 580 x D 340 mm
- RAL 7035 light grey



06

**Universal module 3-fold inclined**  
center module

▶ Item no. 7101-002-012

## ▶ Technical specifications

- Load capacity per shelf 20 kg
- Dimensions: H 544 x W 580 x D 340 mm
- RAL 7035 Light grey



03

**Floor module**  
with plinth panel and a universal floor in 369 mm height

▶ Item no. 7101-001-007

## ▶ Technical specifications

- Supporting force per shelf 20 kg
- Dimensions: H 544 x W 580 x D 340 mm
- RAL 7035 light grey



04

**Floor module**  
with plinth panel and a universal floor in 450 mm height

▶ Item no. 7101-001-008

## ▶ Technical specifications

- Supporting force per shelf 20 kg
- Dimensions: H 544 x W 580 x D 340 mm
- RAL 7035 light grey



07

**Sloping pouring module**  
Final module

▶ Item no. 7101-003-004



08

**Universal module 2-fold inclined**  
Final module

▶ Item no. 7101-003-005



01

**Car bulb cabinet module**

Lockable

▶ Item no. 7101-002-008

▶ Technical specifications

- Storage of 56 car bulbs in foam inlay
- Two compartment shelves with a pitch of 68 mm
- Height-adjustable
- Lockable Plexiglass door
- Stable and high-quality steel construction
- Modular structure with virtually unlimited expansion options
- Fast and simple setup
- Individual planning options
- Optimised stock review and control
- Simple and rapid access to your goods
- Clearly laid-out and space-saving storage of car bulbs, DIN and standard parts, spray canisters, cartridges, fastening materials, workshop requirements and a wealth of other articles



02

**Shelved cabinet module**

Lockable cupboard

▶ Item no. 7101-001-002

▶ Technical specifications

- Three compartment shelves with a pitch of 68 mm
- Height-adjustable
- Lockable metal door
- Stable and high-quality steel construction
- Modular structure with virtually unlimited expansion options
- Fast and simple setup
- Individual planning options
- Optimised stock review and control
- Simple and rapid access to your goods
- Clearly laid-out and space-saving storage of car bulbs, DIN and standard parts, spray canisters, cartridges, fastening materials, workshop requirements and a wealth of other articles



03

**End module**

with perforated board

▶ Item no. 7101-003-002

▶ Technical specifications

- Dimensions: H 444 x W 580 mm x D 340 mm
- Colour RAL 7035 light grey



04

**Perforated board**

Incl. fastening

▶ Item no. 7101-005-002

▶ Technical specifications

- Dimensions: H 896 x 336 mm
- Colour RAL 7035 light grey



05

**Advertising panel**

End module

▶ Item no. 7101-005-000



06

**Shelf connector**

Incl. attachment set

▶ Item no. 7101-005-003



07

**Wall anchoring set**

▶ Item no. 7101-005-004



08

**Threaded rod module**

2-piece kit

▶ Item no. 7101-005-001



01

**Mounting grid**

Item no.	Dimensions Length x height	For storage boxes	
		Size 3	Size 4
7100-001-1	500 x 450 mm	9 x	16 x
7100-001-2	450 x 1000 mm	12 x	32 x
7100-001-3	1000 x 450 mm	18 x	36 x



01

02

**Perforated board**

Incl. fastening

▶ Item no. 7101-005-002

▶ Technical specifications

- Dimensions: H 896 x 336 mm
- Colour RAL 7035 light grey

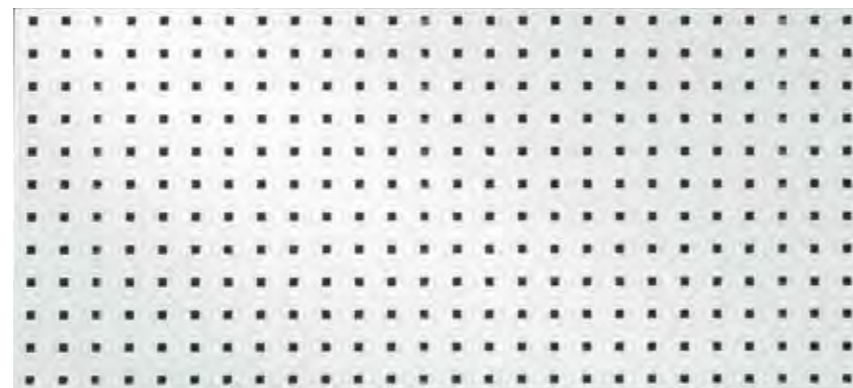

02

03

**Cable dispenser**

▶ Item no. 7100-002-02

▶ Product description

- Holds reels with up to 17 mm spindle size
- Colour: Aluminium colours
- Width: Max. 78/diameter 170 mm



03

04

**Holder for petrol hose/shrink hose**

▶ Item no. 7100-002-03

▶ Product description

- Dimensions: (WxD): 490 mm x 243 mm
- Colour: light grey

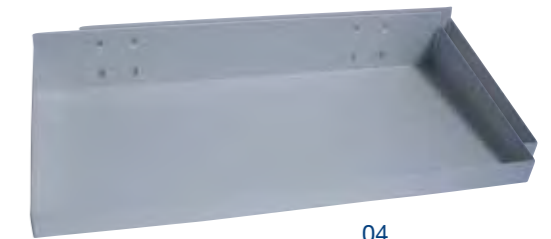

04

05

**Abrasive fleece holder**

empty

▶ Item no. 7100-002-07

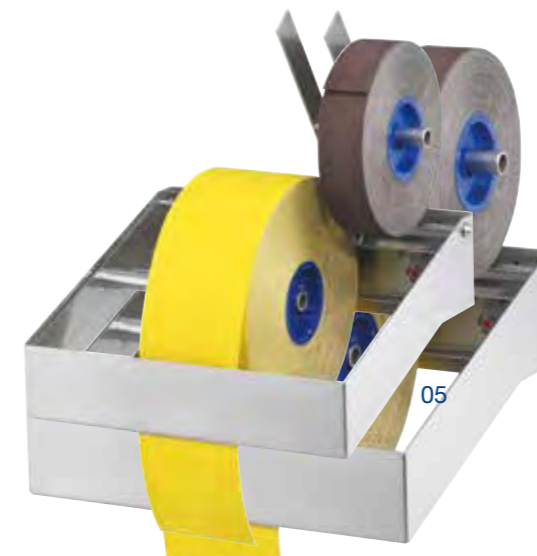

05

06

**Hose clamp display**

empty

▶ Item no. 7100-000

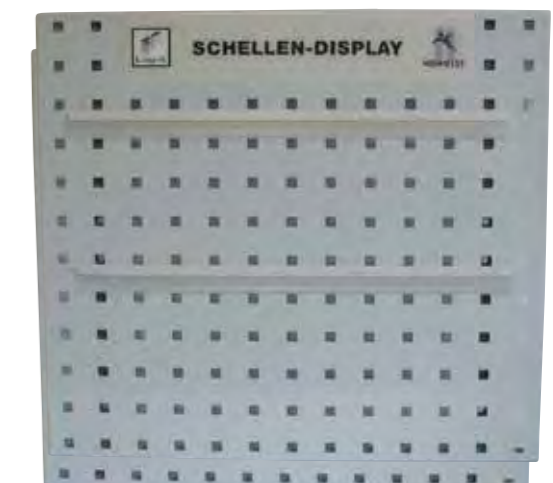

06



01

**Tool holder**  
straight mandril

Item no.	Model
7100-000-304	150 mm

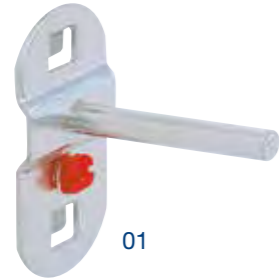

01

02

**Tool clip**  
small

Item no.	Model
7100-000-305	19 mm



02

03

**Tool holder**  
angled mandril

Item no.	Model
7100-000-301	50 mm
7100-000-302	100 mm
7100-000-3	150 mm
7100-000-303	200 mm



03

04

**Round can holder**  
3 times

► Item no. 7100-000-6

► Product description

- Width: 300mm
- Ø 70mm
- Colour: aluminium-coloured

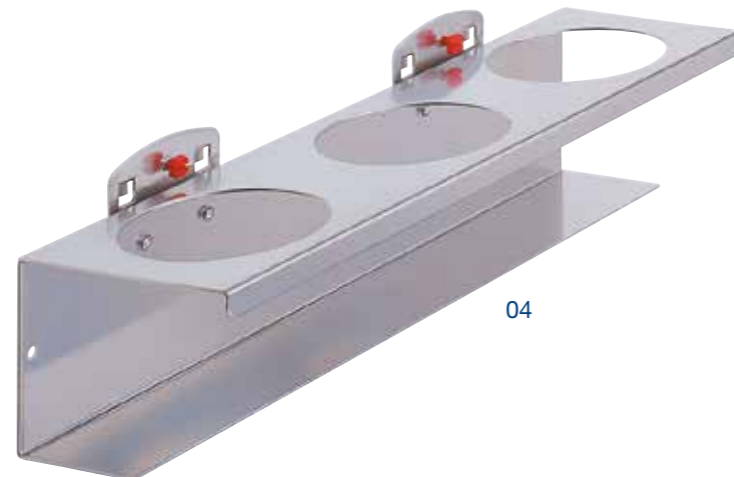

04

05

**Inscription label strip self-adhesive**

Item no.	Model
7100-000-5	430 mm
7100-000-7	940 mm

7100-000-7	940 mm
------------	--------

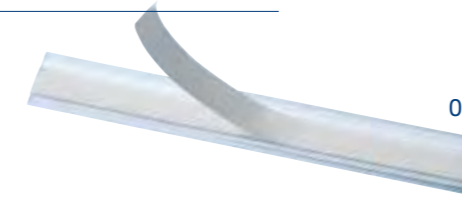

05

06

**Magnetic labels**

Width: 30 mm, length: 80 mm

► Item no. 1961-004-021



06

07

**Magnetic tape roll**

Length: 10.0 m, thickness: 0.65 mm

Item no.	Width
1961-004-201	20 mm
1961-004-251	25 mm

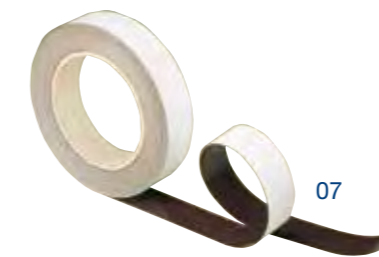

07

08

**Velcro strips**

Self-adhesive, 10 metre X 20 mm

► Item no. 3985-80



08

09

**Holder bar for cans and bottles**  
empty

► Item no. 7100-002-01

► Product description

- Dimensions (HxWxD): 50 mm x 500 mm x 80 mm
- 2 oval holes 22/31 x 57 mm
- 3 round holes 51 mm
- 2 oval holes 20/27 x 46 mm
- 1 round hole 31 mm



09

01

**Storage box size 1**

Length: 500/450 mm, width: 300 mm, height: 180 mm

Item no.	Colour
1962-1-1	blue
1962-2-1	grey



01

02

**Storage box size 2**

Length: 350/300 mm, width: 200 mm, height: 150 mm

Item no.	Colour
1962-2-2	grey
1962-1-2	blue



02

03

**Storage box size 3**

Width: 140 mm, height: 130 mm

Item no.	Colour
1962-1-3	blue
1962-2-3	grey



03

04

**Storage box size 4**

Suitable for mounting grid, length: 160/140 mm  
width: 95 mm, height: 75 mm

Item no.	Colour
1962-1-4	blue
1962-2-4	grey



04

05

**Storage boxes**

Width: 188 mm, height: 80 mm

Item no.	Model
1961-945-291	Labels with protective film
1961-945-30	7-compartment
1961-945-31	5-compartment
1961-945-36	9-compartment
1961-945-34	Separating wall



05

06

**Storage boxes**

Width: 94 mm, height: 80 mm

Item no.	Model
1961-945-33	5-fold
1961-945-32	7-fold
1961-945-37	9-fold
1961-945-35	Partition wall
1961-945-29	Labels with protective film



06

07

**Parts box**

Width: 90 mm, height: 50 mm, length: 270 mm

Item no.	Model
1961-0	Parts box
1961-01	Partition wall
1961-02	Labels



07